

Fiscal Year Ending March 31, 2024

# Financial Results Briefing Materials for 1Q

Announced on July 27, 2023



**PEGASUS CO., LTD.**

【Code : 6262, Tokyo stock exchange in Japan】

- Overview for 1Q of FY2024 ..... 3
- Reference ..... 13
- Corporate Profile ..... 16

# Overview for 1Q of FY2024

---

- ✓ Increase in the number of infected people due to the end of China's zero-COVID policy and the resulting disruption and stagnation of the Chinese economy
- ✓ Prolonged Russian-Ukrainian Situation
- ✓ Exchange rate fluctuations due to monetary policies in the U.S. and European countries and their impact on business activities and consumer spending

## Industrial sewing machine

- ✓ Decrease in orders for sewing factories due to increase in excess apparel inventory
- ✓ Sluggish demand for capital investments in sewing factories
- ✓ Deteriorating exchange rate situations in Asian countries to which our products are supplied

## Automotive parts

- ✓ Stabilization of raw material prices
- ✓ Impact on the automotive industry due to delays in resolving the semiconductor shortage
- ✓ Concentration of the automotive industry in Mexico

# Overview of Net Sales by Business

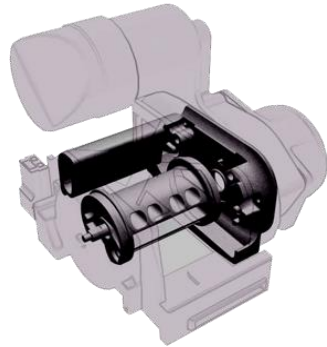
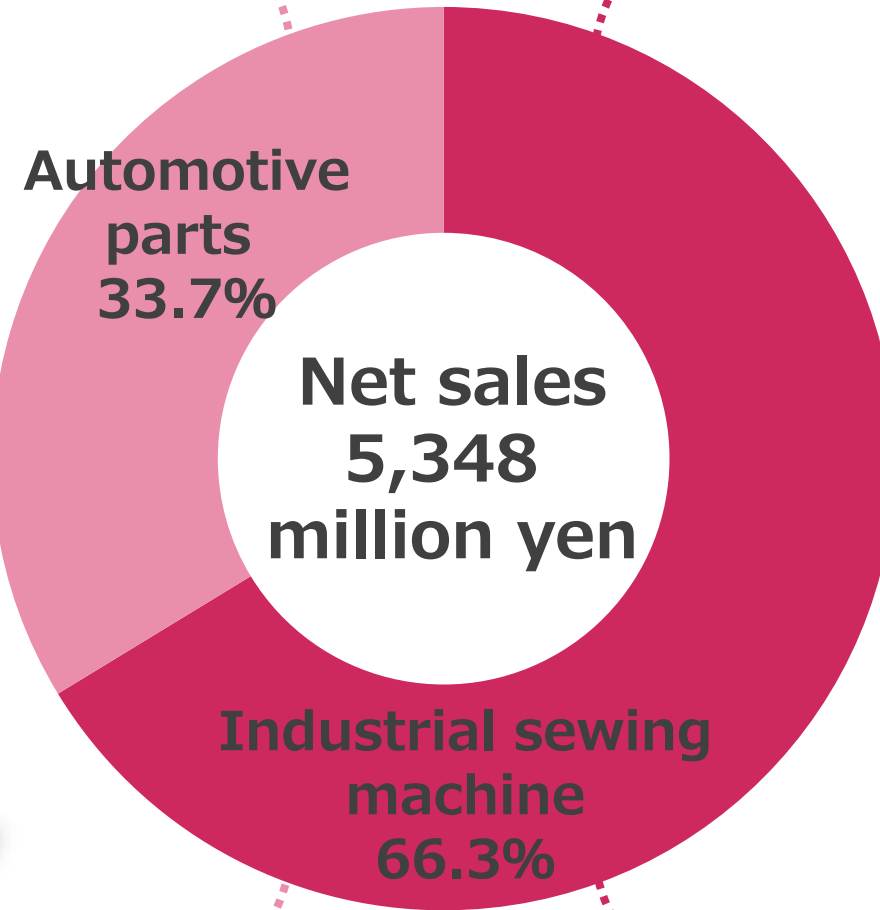
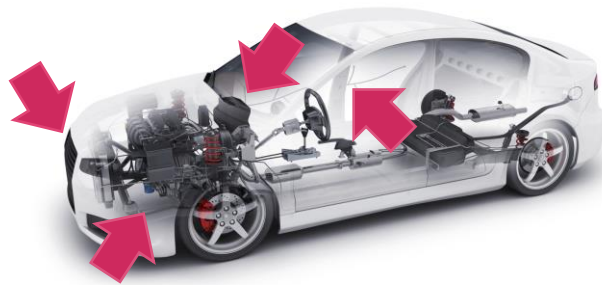

Image of die casting products

Examples use of die casting products



Overedger stitch machines



Interlock stitch machines

# Overview of Consolidated Financial Results



(Million yen: Amounts of less than one million yen are rounded down)  
 (※Results excluding the effects of foreign exchange are indicated in parentheses)

	Previous 1Q	Current 1Q	Change	Percentage change
<b>Net sales</b>	6,847	<b>5,348</b>	△1,498 (△2,016)	△21.9% (△29.4%)
<b>Industrial sewing machines</b>	5,406	<b>3,545</b>	△1,861 (△2,159)	△34.4% (△39.9%)
<b>Automotive parts</b>	1,440	<b>1,803</b>	+362 (+143)	+25.2% (+10.0%)
<b>Operating profit</b>	961	<b>250</b>	△711	△74.0%
<b>Ordinary profit</b>	1,198	<b>586</b>	△611	△51.0%
<b>Profit before income taxes</b>	1,198	<b>586</b>	△611	△51.0%
<b>Profit attributable to owners of parent</b>	900	<b>391</b>	△508	△56.5%

# Net Sales by Business and Location



## Industrial sewing machine

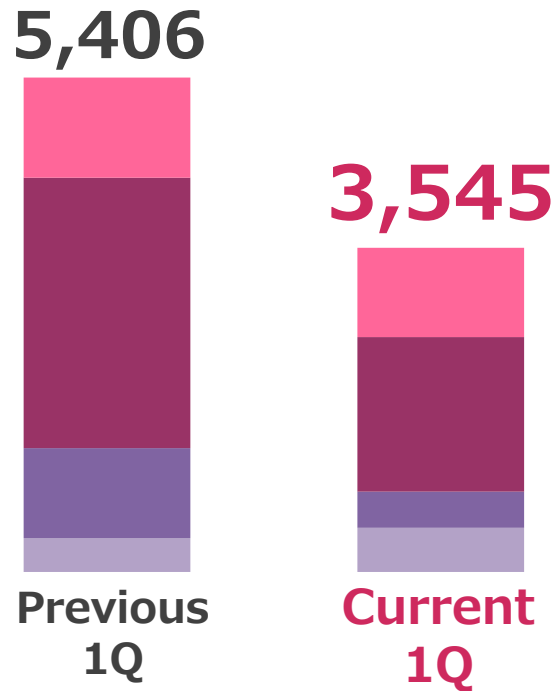

In Asia, net sales decreased from the previous year due in part to the deteriorating exchange rate situations. In the Americas, demand for capital investments in the Central American region, which had been strong until now, slowed down due to production adjustments for sewn products accompanying an increase in apparel inventory. On the other hand, net sales in Europe increased from the previous year due in part to reconstruction demand from the Turkey-Syria earthquake, etc.

**China**

977 million yen  
YoY change :  $\Delta$ 10.7%

**Japan  
Asia**

1,688 million yen  
YoY change :  $\Delta$ 42.9%

**Americas**

396 million yen  
YoY change :  $\Delta$ 59.8%

**Europe**

482 million yen  
YoY change : +31.0%

•Qty. of units sold :  $\Delta$ 51.8%  
•Average unit price : +7.8%  
(Excluding the effects of foreign exchange :  $\Delta$ 0.9%)

(Million yen: Amounts of less than one million yen are rounded down)

# Net Sales by Business and Location



## Automotive parts

Despite the impact of the semiconductor shortages in the automotive industry, net sales increased from the previous year.

In the Americas, in particular, the company's ongoing efforts to acquire new customers and win new orders from existing customers bore fruit, resulting in a significant increase in net sales compared to the previous year.

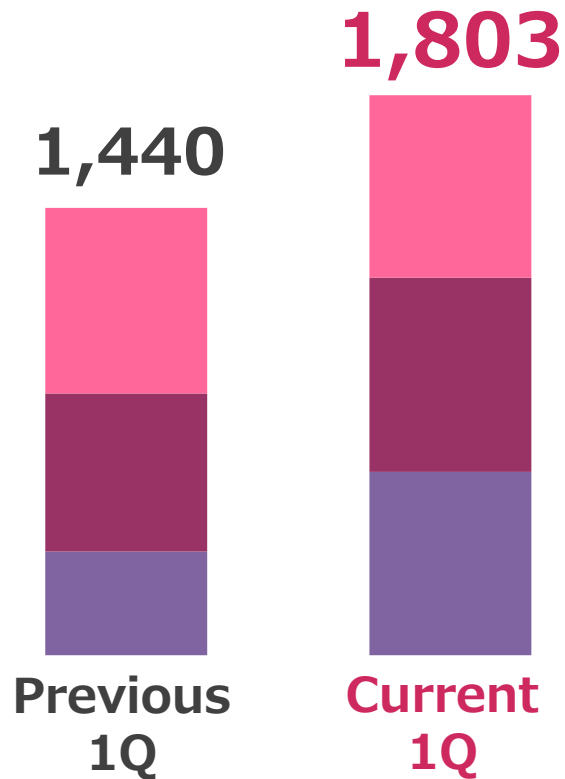

<b>China</b>	587 million yen YoY change : $\Delta 1.7\%$
<b>Asia</b>	624 million yen YoY change : +22.8%
<b>Americas</b>	590 million yen YoY change : +77.0%

(Million yen: Amounts of less than one million yen are rounded down)



# Changes in Operating Profit

- ✓ Decrease in revenue and profit from the previous year due to significant decrease in net sales

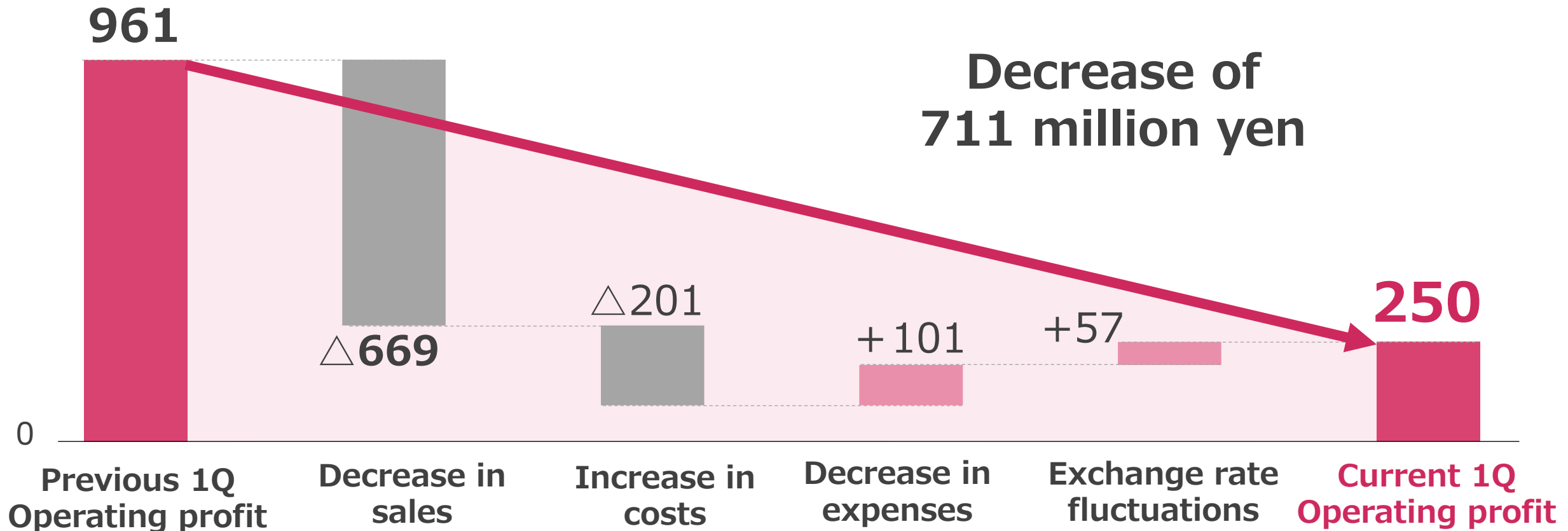

(Million yen: Amounts of less than one million yen are rounded down)

# Consolidated Balance Sheets



(Million yen: Amounts of less than one million yen are rounded down)

	End of previous year	Current 1Q	Change	Main factors contributing to changes
Current assets	28,372	<b>28,205</b>	△166	<ul style="list-style-type: none"> <li>•Notes and accounts receivable - trade +526</li> <li>•Merchandise and finished goods △176</li> </ul>
Non-current assets	11,135	<b>12,329</b>	+1,194	<ul style="list-style-type: none"> <li>•Property, plant and equipment +1,023</li> <li>•Intangible assets △2</li> <li>•Investments and other assets +172</li> </ul>
Total assets	39,507	<b>40,535</b>	+1,027	

	End of previous year	Current 1Q	Change	Main factors contributing to changes
Current liabilities	7,863	<b>8,175</b>	+311	<ul style="list-style-type: none"> <li>•Notes and accounts payable - trade △421</li> <li>•Short-term borrowings +790</li> </ul>
Non-current liabilities	2,444	<b>2,713</b>	+268	<ul style="list-style-type: none"> <li>•Long-term borrowings △74</li> </ul>
Net assets	29,199	<b>29,647</b>	+447	<ul style="list-style-type: none"> <li>•Retained earnings +93</li> <li>•Foreign currency translation adjustment +387</li> </ul>
Total liabilities and net assets	39,507	<b>40,535</b>	+1,027	

(Major changes in primary accounts are presented above)

# Consolidated Financial Position



(Amounts of less than one million yen are rounded down)

	<b>End of previous year</b>	<b>Current 1Q</b>
Equity (million yen)	28,300	<b>28,783</b>
Capital adequacy ratio (%)	71.6	<b>71.0</b>

	<b>End of previous year</b>	<b>Current 1Q</b>
BVPS (yen)	1,140.65	<b>1,160.12</b>
Year-end share price (yen)	634	<b>587</b>
PBR (times)	0.56	<b>0.51</b>

(Amounts of less than one million yen are rounded down)

	<b>Previous 1Q</b>	<b>Current 1Q</b>
Profit attributable to owners of parent (million yen)	900	<b>391</b>
EPS (yen)	36.28	<b>15.79</b>

# Capital investment・Depreciation・R&D expenses



(Million yen: Amounts of less than one million yen are rounded down)

	Previous 1Q	Current 1Q	Change
Capital investment	287	637	+349
Depreciation	217	258	+41
R&D expenses	64	114	+49

<Main capital investments> (Million yen: Amounts of less than one million yen are rounded down)

Company name	Details	Total investment
PEGASUS VIETNAM SEWING MACHINE CO., LTD.	Construction costs of new factory, etc.	437
PEGASUS AUTO PARTS MONTERREY S.A. DE C.V.	Expansion of production facilities, etc.	95
PEGASUS(TIANJIN) SEWING MACHINE CO., LTD.	Installation of production facilities, etc.	29

# Reference

---

## Net Sales by Business and Location (YoY change excluding the effects of foreign exchange)

(Amounts of less than one million yen are rounded down)

Industrial sewing machine		China	Japan Asia	Americas	Europe	Total
Current 1Q	Net sales (million yen)	977	1,688	396	482	3,545
	YoY change (%)	△10.7	△42.9	△59.8	+31.0	△34.4
	YoY change excluding the effects of foreign exchange (%)	△14.8	△48.5	△64.7	+20.1	△39.9
Previous 1Q	Net sales (million yen)	1,095	2,957	985	368	5,406

(Amounts of less than one million yen are rounded down)

Automotive parts		China	Asia	Americas	Total
Current 1Q	Net sales (million yen)	587	624	590	1,803
	YoY change (%)	△1.7	+22.8	+77.0	+25.2
	YoY change excluding the effects of foreign exchange (%)	△6.2	+8.0	+42.1	+10.0
Previous 1Q	Net sales (million yen)	597	508	333	1,440

# Reference



## Effects of foreign exchange (based on consolidated net sales for 1Q of FY2024)

Currencies	JPY	USD	EUR	RMB	MXN	Results for the current year	Excluding the effects of foreign exchange	Results for the previous year	YoY change excluding the effects of foreign exchange
Exchange rates for the period	–	¥133.26	¥143.34	¥19.33	¥7.14	–	–	–	–
Exchange rates for the previous period	–	¥117.12	¥131.35	¥18.44	¥5.73	–	–	–	–
Difference (yen)	–	16.14	11.99	0.89	1.41	–	–	–	–
Net sales	326	2,383	482	1,565	590	<b>5,348</b>	<b>4,830</b>	6,847	△2,016
Ratio (%)	6.1	44.6	9.0	29.3	11.0	100.0	–	–	–
<b>Change in foreign exchange</b>	<b>–</b>	<b>288</b>	<b>40</b>	<b>72</b>	<b>116</b>	<b>517</b>	<b>–</b>	<b>–</b>	<b>–</b>
Cost of sales	△690	1,504	15	2,533	454	<b>3,817</b>	<b>3,427</b>	4,573	△1,145
Ratio (%)	△18.1	39.4	0.4	66.4	11.9	100.0	–	–	–
<b>Change in foreign exchange</b>	<b>–</b>	<b>182</b>	<b>1</b>	<b>116</b>	<b>89</b>	<b>389</b>	<b>–</b>	<b>–</b>	<b>–</b>
Selling and administrative expenses	501	386	66	308	17	<b>1,280</b>	<b>1,210</b>	1,312	△101
Ratio (%)	39.2	30.2	5.2	24.1	1.3	100.0	–	–	–
<b>Change in foreign exchange</b>	<b>–</b>	<b>46</b>	<b>5</b>	<b>14</b>	<b>3</b>	<b>69</b>	<b>–</b>	<b>–</b>	<b>–</b>
Operating profit	515	492	400	△1,276	118	<b>250</b>	<b>192</b>	961	△769
<b>Change in foreign exchange</b>	<b>–</b>	<b>59</b>	<b>33</b>	<b>△58</b>	<b>23</b>	<b>57</b>	<b>–</b>	<b>–</b>	<b>–</b>
Cost of sales ratio (%)	–	–	–	–	–	<b>71.4</b>	<b>71.0</b>	<b>66.8</b>	–

(Million yen: Amounts of less than one million yen are rounded down except for Exchange rates, ratio, Cost of sales ratio)

# Corporate Profile

---



## Corporate Philosophy

Through our people & technology, we strive to provide better Products, Service and Quality and make a positive contribution to the world of "social development"

## Basic Policy for Business

- We deepen exchanges with people throughout the world, and develop reliable business activities. Deploying people and products throughout the world we plan our activities with respect for universal values.
- Always striving to master Pegasus's core technology we aim for superior global quality manufacturing. Striving to attain the position of the "true, leading manufacturer of chain-stitch sewing machines", we supply our products at optimum quality, optimum price and with optimum lead times.
- We always learn from our customers, form their needs into tangible shape, and utilizing this offer services and information. Constantly learning from customers and always maintaining the truth is the spirit that supports all of Pegasus's business activities.
- By building on the relations with our associates and employees we aim for mutual growth and development. By the handing down of our predecessors' originality and ingenuity we oversee the creation of new ideas. And these endeavors lead to personal development of our employees and, needless to say of course, also our associates.

# Corporate Profile



Name

PEGASUS CO., LTD.

Representative

Representative Director and President Shigemi Mima

Founded

January, 1914

Location

Fukushima-ku, Osaka, Japan

Capital

2,255.55million yen (as of March,2023)

Sales

25,288.50million yen (From April 1, 2022 to March 31, 2023)

Number of employees

1,485 [consolidated]  
197 [non-consolidated] (as of March,2023)

Business

- Manufacture and sale of industrial chain stitching sewing machines and parts
- Manufacture and sale of die casting auto parts and other automotive parts

## ◆Principal Shareholders

Shareholder's Name	Holding Ratio
Custody Bank of Japan, Ltd. (Trust Account)	9.85%
The Master Trust Bank of Japan Ltd. (Trust Account)	7.77%
MIMA Co.,LTD.	6.26%
Sumitomo Mitsui Banking Corporation	3.35%
Keizo Bando	2.99%
Takako Yoshida	2.86%
Shigemi Mima	2.55%
Masamichi Mima	1.91%
Nomura Securities Co.,Ltd.	1.52%
Masako Tamura	1.49%

## ◆Breakdown of Shareholders by Type (%)

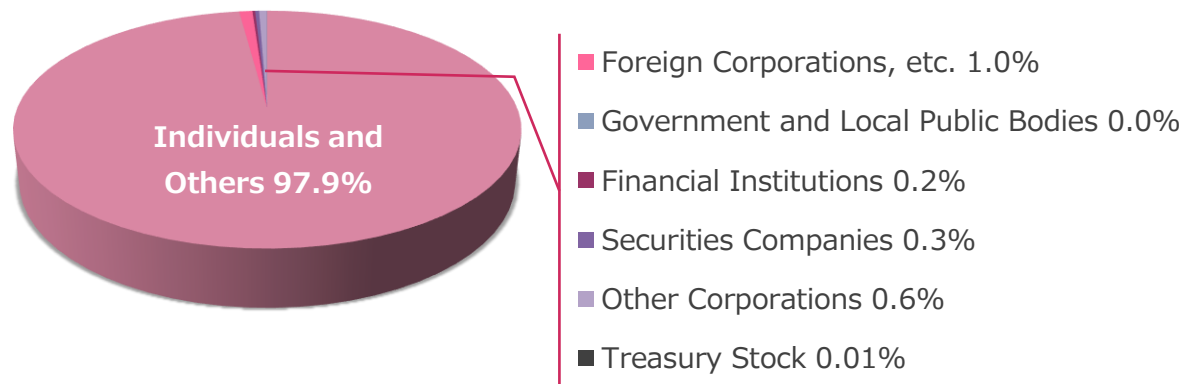

## ◆Breakdown of Shares by Type of Shareholder (%)

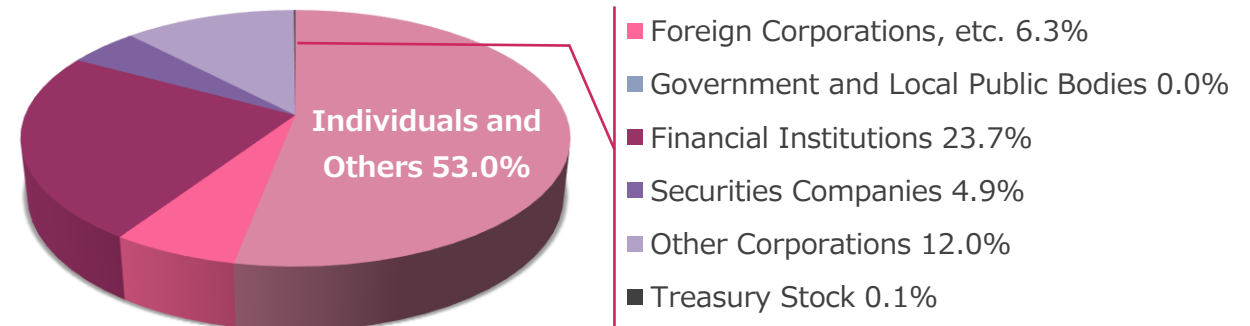

# Changes in Consolidated Financial Results

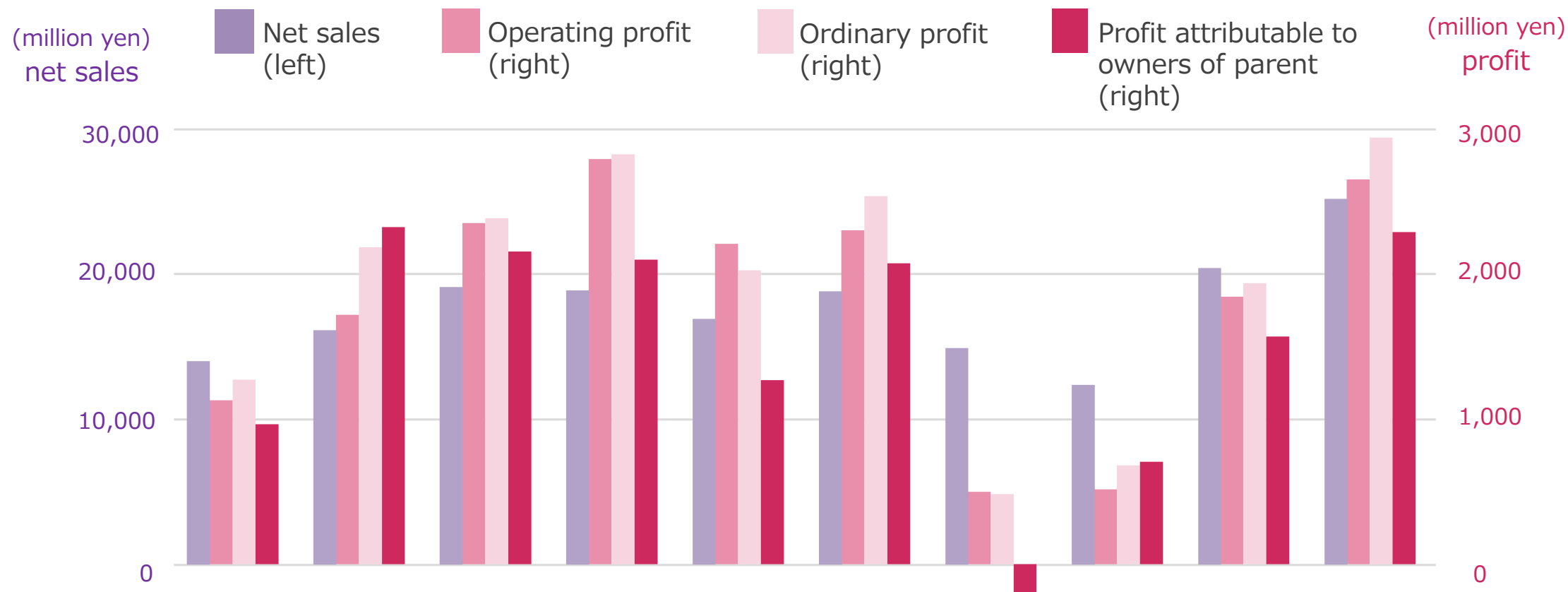

	FY2014	FY2015	FY2016	FY2017	FY2018	FY2019	FY2020	FY2021	FY2022	FY2023
Net sales	14,067	16,206	19,188	18,961	16,978	18,891	14,969	12,422	20,498	25,288
Operating profit	1,118	1,723	2,356	2,798	2,212	2,306	499	516	1,847	2,657
Ordinary profit	1,260	2,189	2,388	2,831	2,030	2,542	484	681	1,941	2,946
Profit attributable to owners of parent	953	2,328	2,160	2,103	1,270	2,079	▲206	707	1,572	2,294

(Million yen: Amounts of less than one million yen are rounded down)



Notes regarding this document:

Financial results forecast and other forward-looking information contained in this document are based on information currently available to the Company as well as estimates on the economic environment, and are therefore subject to a number of uncertainties.

Actual results may differ from these forecasts due to a variety of factors.

The Company does not guarantee the accuracy of any information provided in this document.